

技术参数 Specifications

电气参数 Ratings:

- ◇最大工作电压
Max. Switching Voltage: 1500VDC
- ◇额定电流
Rated Current: 600A
- ◇主触点形式
Main Contact Type: 一组常开 SPST-NO
- ◇辅助触点
Auxiliary Contact: 一组常开/常闭 SPST-NO/NC
- ◇辅助触点形式
Auxiliary Contact Type: 可选 Optional
- ◇线圈额定电压
Coil Rated Voltage : 12VDC\ 24VDC\ 9-36VDC
- ◇使用环境温度
Ambient Operation Temperature : -40°C~+85°C
- ◇使用环境湿度
Ambient Operation Humidity : 5%~85%RH



认证/标准 Approvals/Standard:

- ◇REACH
- ◇RoHS
- ◇CE
- ◇UL

产品特征 Features&Benefits:

产品结构紧凑，全密封封装，内部充有惰性气体，结合磁吹灭弧能快速的熄灭电弧，使产品外形可以做到很小；
Compact structure, fully sealed package, internal filled with inert gas, combined with magnetic arc blowing out can quickly extinguish the arc, so that the product shape can be small;

环氧树脂封装，触点部分密封在充有惰性气体的密封腔内，触点无氧化，电弧无外泄，从而保证产品具有良好的安全性；
Epoxy resin package, the contact part is sealed in thesealed chamber filled with inert gas, contact no oxidation, arc noeakage, so as to ensure that the product has good safety;

能够在85°C环境下持续承载600A电流；
Carrying current 600A continuously at 85°C;

产品型号说明 Product Model:

	HC	Z03	600	F	-A	P	- ()
公司代码 Company Code							
系列代码 Series Code	Z03:Z03系列 Z03 Series						
触点容量（额定电流） Contact Rating(Rated Current)	600:600A						
辅助触点 Auxiliary Contact	无 Nil: 无辅助触点 No Auxiliary Contact F: 一组常开 SPST-NO B: 一组常闭 SPST-NC						
线圈电压 Coil Voltage	12:12VDC; 24:24VDC; A:9-36VDC;						
主触点形式 Main Contact Type	无 Nil: 一组常开，无极性 SPST-NO, Non-Polarized P: 一组常开，有极性 SPST-NO, Polarized						
特性号 Special Code	XXX: 客户特殊要求 Customer Special Code; 无 Nil: 标准性 Standard						

HCZ03-600-A

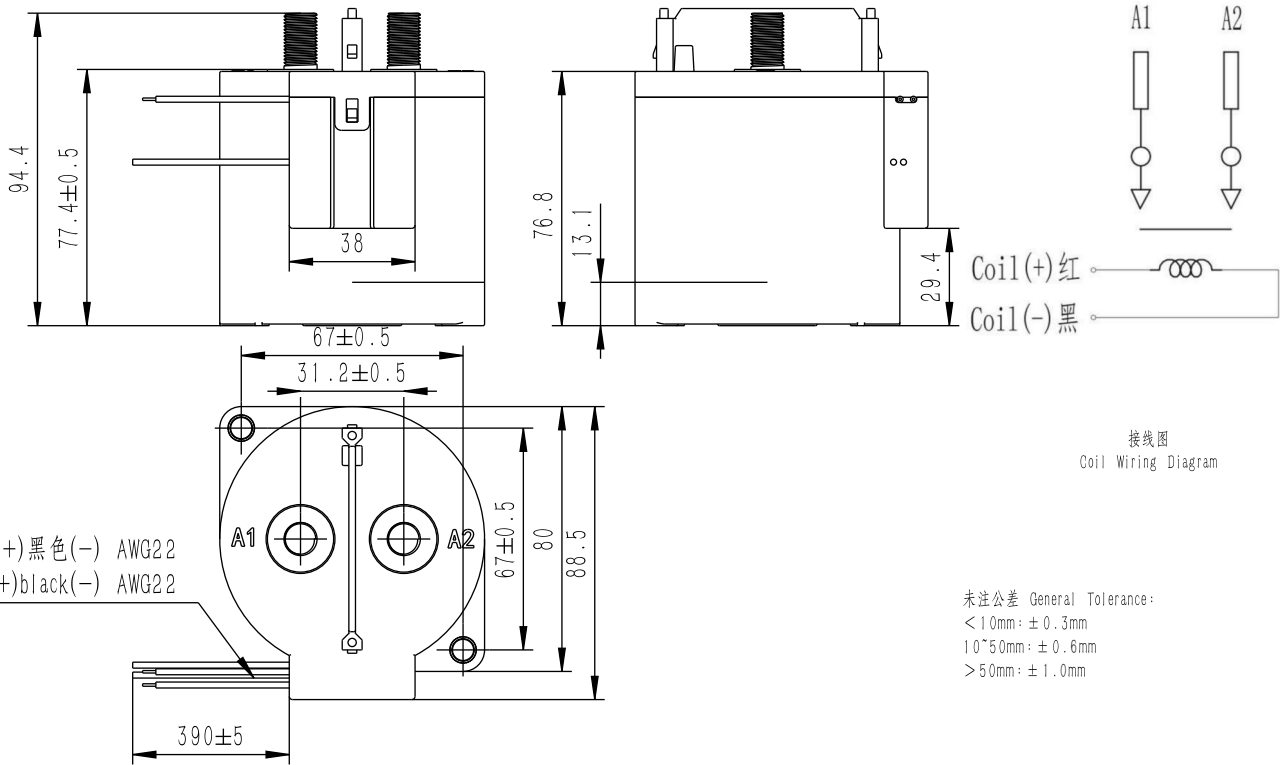

特性参数 CHARAC TERISTIC PARAMETERS

主触点参数 MAIN CONTACT DATA

最大工作电压 Max. Switching Voltage	1500VDC	额定电流 Rated Current	600A
触点形式 Contact Arrangement	一组常开 SPST-NO	触点压降 Contact Voltage Drop	≤0.03V(at 600A)
短时承载电流 Limiting Short-time Current	750A:600sec;1500A:20sec		
电寿命 (阻性负载) Electrical Life (Resistive Load)	600A 750VDC,500次(ops)	400A 1000VDC,700次(ops)	200A 1500VDC,1000次(ops)
最大分断电流 (阻性负载) Max. Breaking Current (Resistive Load)	3000A320Vdc1次(ops)		

性能参数 CHARACTERISTIC DATA

介质耐压 Dielectric Strength	主触点与线圈间 Between Main Contacts and Coil	试验前 Before Test≥4500VAC (1min)	绝缘电阻 Insulation Resistance	主触点与线圈间 Between Main Contacts and Coil	试验前 Before Test≥1000MQ(1000VDC) 试验后 After Test≥50MQ (1000VDC)
	断开主触点间 Between Open Main Contacts	试验前 Before Test≥4500VAC (1min)		断开主触点间 Between Open Main Contacts	试验前 Before Test≥1000MQ(1000VDC) 试验后 After Test≥50MQ (1000VDC)
耐冲击 Shock Resistance	功能性 Functional	196m/s²(20G以上)20G above	耐振动 Vibration Resistance	功能性 Functional	10~500HZ,49m/s²
	强度 Destructive	490m/s²(50G以上)50G above			
吸合时间 Operate Time	Max:50ms	机械寿命 Mechanical Life	2x10 ⁵ 次 (ops)		
释放时间 Release Time	Max:30ms	重量 Weight	约 Approx 1110g		

线圈参数 COIL DATA

额定电压 Rated Voltage	9-36VDC
吸合电压 Pick-up Voltage	≤9VDC
释放电压 Drop-out Voltage	≥6VDC
线圈功率 Rated Operating Power	启动功率: 44W 保持功率: 4W
线圈电阻±7% Coil resistance	4.1Ω

HCZ03-600F-A

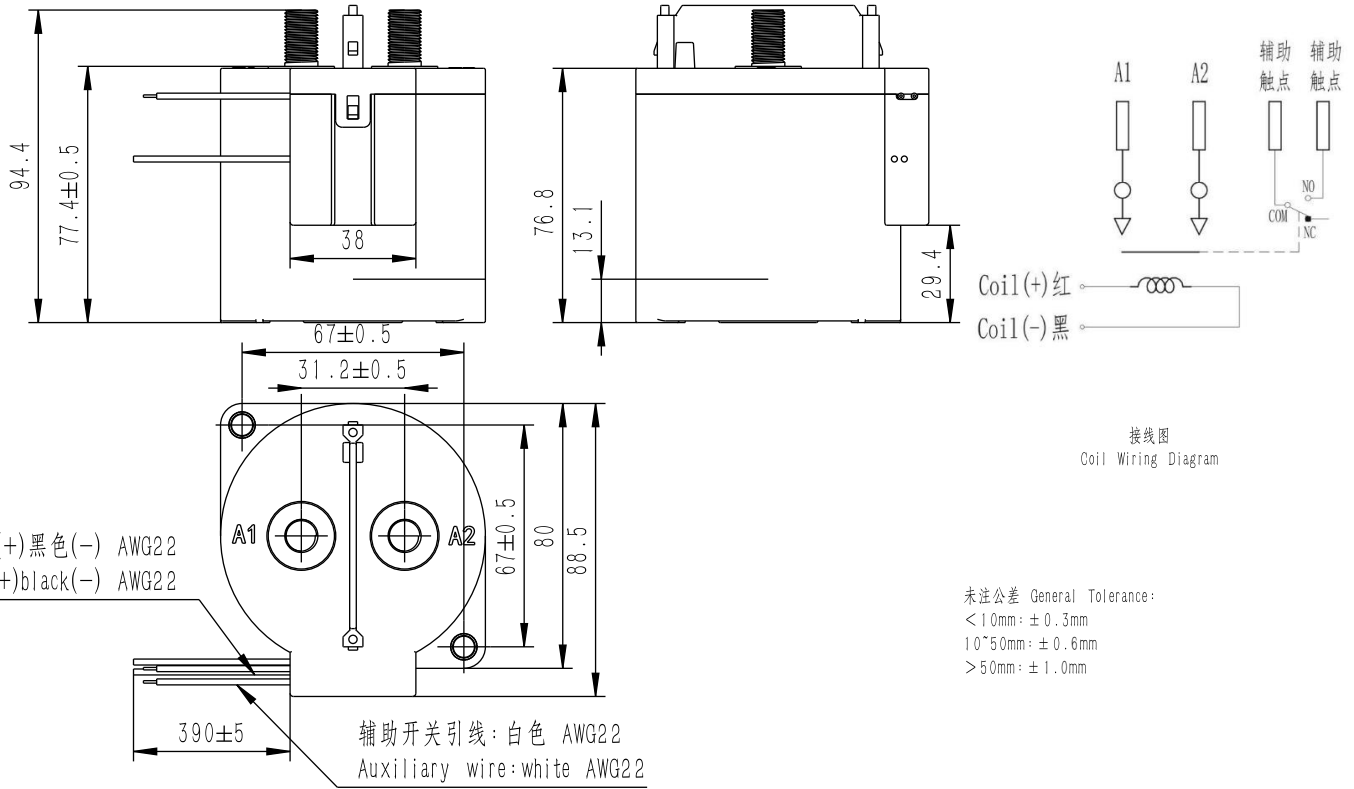

特性参数 CHARAC TERISTIC PARAMETERS

主触点参数 MAIN CONTACT DATA

最大工作电压 Max. Switching Voltage	1500VDC	额定电流 Rated Current	600A
触点形式 Contact Arrangement	一组常开 SPST-NO	触点压降 Contact Voltage Drop	≤0.03V(at 600A)
短时承载电流 Limiting Short-time Current	750A:600sec;1500A:20sec		
电寿命 (阻性负载) Electrical Life (Resistive Load)	600A 750VDC,500次(ops)	400A 1000VDC,700次(ops)	200A 1500VDC,1000次(ops)
最大分断电流 (阻性负载) Max. Breaking Current (Resistive Load)	3000A320Vdc1次(ops)		

性能参数 CHARACTERISTIC DATA

介质耐压 Dielectric Strength	主触点与线圈间 Between Main Contacts and Coil	试验前 Before Test≥4500VAC (1min)	绝缘电阻 Insulation Resistance	主触点与线圈间 Between Main Contacts and Coil	试验前 Before Test≥1000MQ(1000VDC) 试验后 After Test≥50MQ (1000VDC)
	断开主触点间 Between Open Main Contacts	试验前 Before Test≥4500VAC (1min)		断开主触点间 Between Open Main Contacts	试验前 Before Test≥1000MQ(1000VDC) 试验后 After Test≥50MQ (1000VDC)
耐冲击 Shock Resistance	功能性 Functional	196m/s²(20G以上)20G above	耐振动 Vibration Resistance	功能性 Functional	10~500HZ,49m/s²
	强度 Destructive	490m/s²(50G以上)50G above			
吸合时间 Operate Time	Max:50ms	机械寿命 Mechanical Life	2x10 ⁵ 次 (ops)		
释放时间 Release Time	Max:30ms	重量 Weight	约 Approx 1110g		

线圈参数 COIL DATA

额定电压 Rated Voltage	9-36VDC
吸合电压 Pick-up Voltage	≤9VDC
释放电压 Drop-out Voltage	≥6VDC
线圈功率 Rated Operating Power	启动功率: 44W 保持功率: 4W
线圈电阻±7% Coil resistance	4.1Ω

使用注意事项 Caution:

- 规格书内的各项性能参数是基于标准测试条件下测得的初始值。
All the performance parameters listed in this specification are deemed as initial value measured under standard testing conditions.
- 使用环境温度-40°C~+85°C，湿度5%~85%RH。
Used in environment temperature -40°C~+85°C, humidity 5%~85%RH.
- 请避免安装在强磁场（变压器、磁铁周围）或发热物体附近。
Please avoid installing the device near high magnetic fields (eg.transformers or magnetics) or hot objects.
- 电寿命试验为阻性负载时的数值，应用在L/R≥1ms的感性负载回路时，请与感性负载并行采取浪涌吸收措施。未采取措施的情况下，可能会成电气寿命下降、发生切断不良。
The electrical life test is performed with resistive load. Therefore, please take surge absorption measures in parallel with inductive load when the device is applied to inductive load circuit with L/R≥1ms. Otherwise, the electrical life is likely to decline, resulting in poor cutting off.
- 应用在容性负载回路时，请注意采取预充等措施，建议接触器闭合压差控制在20V以内。如未采取措施，可能会造成触点粘连。
Measures including precharging etc. must be taken if the device is to be applied in capacitive load circuit.It is suggested that the differential pressure be controlled within 20V when the contactor is in closed position. Otherwise, it might lead to contact adhesion.
- 为抑制接触器线圈的反向电动势，建议加装非线性电阻（推荐使用可变电阻，最大能量耐量：1J以上；电压：额定电压的1.5~2倍）。若使二极管，会使接触器释放时间加长，会导致切断性能下降，请注意。
It is recommended to install a non-linear resistor(Variable resistors are preferred with over 1J maximum energy tolerance and 1.5-2 times of rated voltage)to suppress the reverse electromotive force generating from the contactor coil. Please be noted that the using of diode will prolong the release time of contactor, leading to degradation of cut-off performance.
- 请避免在引出端上粘附油脂等异物，建议使用200mm²以上规格导线，否则有可能造成引出端异常发热。
Please avoid adhering such foreign matters as grease etc. on the leading-out terminals. Over 200mm² conductors shall be used. Otherwise, it will casue abnormal heating of leading-out terminals.
- 请避免在使用或运输过程中发生撞击或跌落。为保持产品的性能，撞击或跌落后不建议继续使用。
Please avoid collision or falling during use or transportation. In order to maintain the performance of the product, it is not recommended to continue to use it after impact or fall.
- 当产品使用1个及多个导电铜排连接时，请确保导电铜排与触点端面紧密贴合（多个铜排需确保大电流的导电铜排最贴近触点端面，小电流的导电铜排其次），然后是平垫圈、弹簧垫圈、螺钉。不正确的连接顺序可能造成严重过热，参考下图1：
When the product is connected with one or more conductive copper bars, please ensure that the conductive busbars closely fit the contact terminal surface (The conductive copper bars with high current must be closet to the contact terminal surface if there are multiple copper bars and then conductive busbars with low current), followed by flat washers, spring washers and screws.Incorrect connection sequence perhaps give rise to severe overheating. Refer to Figure 1 as follows:
- 螺钉安装时，螺纹咬合深度不能过浅，否则有可能导致滑牙松脱，建议咬合深度至少螺纹深度的2/3。
When installing the screws, the thread engagement depth shall not be too shallow, otherwise it may cause the sliding teeth to become loose. It is recommended that the engagement depth be at least 2/3 of the thread depth.
- 为防止出现松动，接触器安装时请使用垫圈螺钉锁紧，各部位的螺钉锁紧扭矩请控制在以下范围：
To prevent looseness, the contactor shall be locked with washer screws during installation, and the screw locking torque of each part shall be controlled within the following range:

主负载安装部位 Main loading installation part				接触器壳体安装部位(图2) Contactor shell installation department (figure 2)		
安装方式 Installation method	扭矩要求 Torque requirements	铜排孔径 Diameter of busbar	铜排厚度 Busbar thickness	安装方式 Installation method	扭矩要求 Torque requirements	底板孔径 Diameter of baseboard
M10螺钉 Screw	10.0N·m~12.0N·m	∅10mm~∅10.5mm	3~4mm	M5螺钉 Screw	3.0N·m~4.0N·m	M5

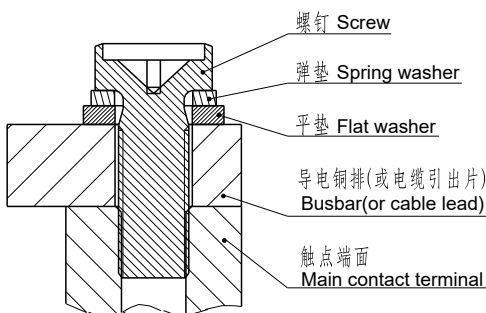

图1(Fig1)

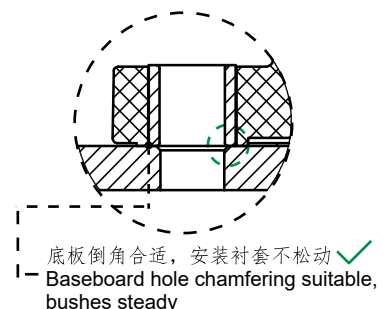
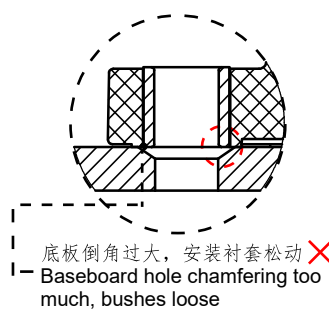

图2(Fig2)